



ISG>PACK
AUTOMATIC PACKAGING SYSTEM

FASCETTATRICI AUTOMATICHE
AUTOMATIC BANDING MACHINES



EASY BAND 35-250 - 25-200



La linea Easy Band 35-250 e 25-200 fanno parte della linea di fascettatrici automatiche da banco, semplici da utilizzare. Utilizzano nastri in polipropilene di larghezza 12 mm. Possono avere un funzionamento manuale o automatico con sensore ed i loro parametri vengono gestiti da pannello touch screen a colori posto nella parte frontale della macchina. Entrambe le macchine hanno un portabobine situato all'interno di un cassetto posto nella parte inferiore della macchina. Sono particolarmente adatte per utilizzo nelle arti grafiche, abbinamento di più prodotti nelle vendite promozionali, profumerie, frutterie ecc.



Easy Band 35-250 and 25-200, simple and reliable, are part of the range of tabletop automatic banding machines. They can work with paper and polypropylene bands of 12mm width. Manual or automatic functioning by sensor and settings adjustable by color touch screen located on the front of the machine. Both machines have a band roll holder placed at the bottom of machine. They are used in particular in the graphic arts for packing various products for promotional offers, in fruit shops, perfumery etc



Utilizzo: Selezionando la modalità automatica, basta appoggiare il prodotto sul piano della fascettatrice. Una fotocellula, leggendo il prodotto, avvia il ciclo di fascettatura e saldatura. Rimuovendo il prodotto la macchina effettua il rilancio, preparandosi alla fascettatura successiva. Selezionando il ciclo manuale, l'operatore avvia la fascettatura manualmente tramite pulsante. La sostituzione del rotolo di fascetta è veloce e semplice.

Use: Selecting the automatic mode and just placing the product on the worktable of the banding machine, the banding and sealing cycle is activated by a photocell that reads the product. When the product is removed, the machine re-feeds the band and prepares itself for the next banding. Selecting the manual cycle, the operator starts a manual banding by button. The replacement of the band roll is quick and easy.

Caratteristiche tecniche

- ⊕ Design compatto
- ⊕ Portabobine interno alla macchina
- ⊕ Display digitale visualizzatore
- ⊕ Regolazione dei parametri direttamente da pannello comandi
- ⊕ Piani di lavoro removibili per una rapida manutenzione
- ⊕ Gruppo di fascettatura con motori 24 vcc
- ⊕ Regolazione tramite ghiera per il tensionamento della fascetta
- ⊕ Sistema di fascettatura manuale o automatica tramite sensore
- ⊕ Regolazione del tempo di saldatura
- ⊕ Regolazione del tempo tra una fascettatura e l'altra (solo in modo automatico)
- ⊕ Regolazione del tempo di lancio della fascetta
- ⊕ Selezione lingua
- ⊕ Macchina conforme alle direttive CE

Technical details

- ⊕ Compact design
- ⊕ Coil holder inside the machine
- ⊕ Digital display
- ⊕ Parameters adjustable by control panel
- ⊕ Removable worktable for a fast maintenance
- ⊕ Banding head with 24 vcc motors
- ⊕ Band tensioning adjustable by screw
- ⊕ Manual or automatic banding by sensor
- ⊕ Adjustable welding time
- ⊕ Adjustable time between one banding and another (only auto mode)
- ⊕ Adjustable out feeding time of the band
- ⊕ Language selection
- ⊕ The machine complies with CE directives

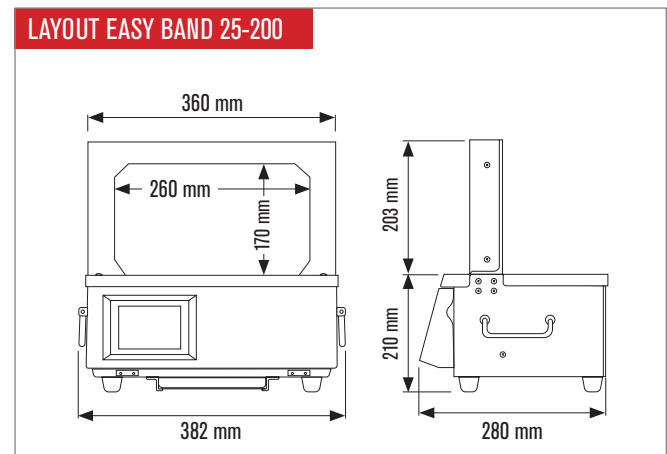
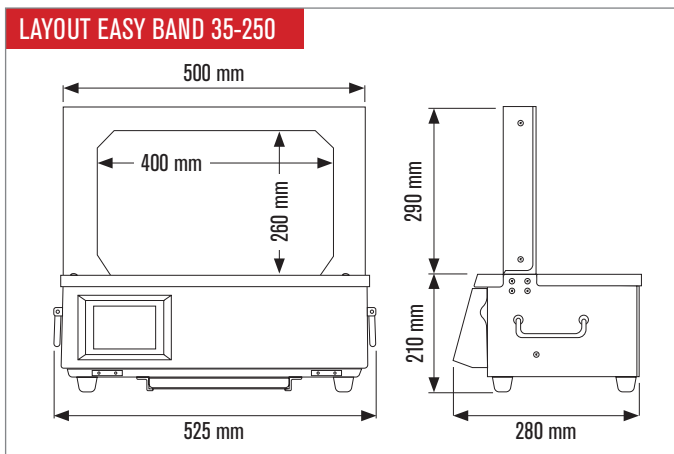

DATI TECNICI DATA SHEET	EASY BAND 35-250	EASY BAND 25-200
Alimentazione elettrica Power supply	220 Volts - 1 Ph - 50 / 60 Hz	220 Volts - 1 Ph - 50 / 60 Hz
Portabobina Coil holder	Integrato Integrated	Integrato Integrated
Velocità al minuto Speed per minute	25 cicli / min 25 cycles / min	25 cicli / min 25 cycles / min
Tipo di fascetta Band type	OPP Film	OPP Film
Tensione di fascettatura Banding tension	5 - 40 N	5 - 40 N
Chiusura Closure	Termosaldatura Heat sealing	Termosaldatura Heat sealing
Larghezza fascetta Band width	12 mm	12 mm
Spessore fascetta Band thickness	120 my	120 my
Dimensione min. prodotto Min. product size	W 30 x H 10 mm	W 30 x H 10 mm
Dimensione max. prodotto Max. product size	W 360 x H 260 mm	W 220 x H 170 mm
Diametro interno bobina Internal roll diameter	40 mm	40 mm
Diametro esterno bobina External roll diameter	Max 160 mm	Max 160 mm
Peso netto Net weight	22 Kg	18 Kg
Dimensione macchina Machine dimension	L 525 x W 280 x H 500 mm	L 382 x W 280 x H 413 mm
Livello di rumorosità Noise level	Conforme a DIN 45635/27 Complying with DIN 45635/27	Conforme a DIN 45635/27 Complying with DIN 45635/27



ISG>PACK
AUTOMATIC PACKAGING SYSTEM

🌐 www.isg-pack.com @ info@imballaggiservice.com

Via Castelli Romani Km. 11,700 | Angolo Via Sassuolo, 6
00071 Pomezia | Roma | Italy
T. +39.06.9160.7561 | F. +39.06.9162.5014



VISITA IL SITO WEB

